

# Marshall Electronics

V-MD171X

17" High Resolution Rack Mountable Monitor

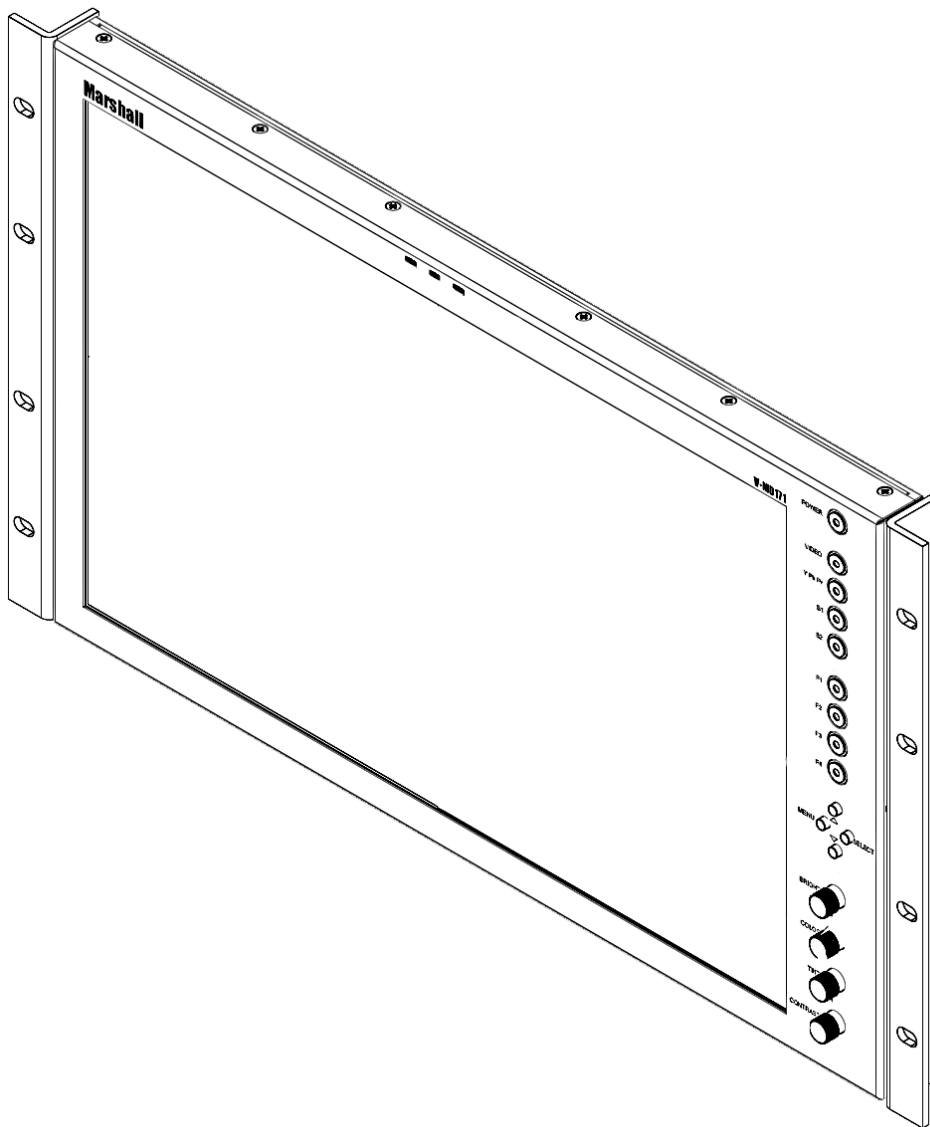

## Operating Instructions

# Contents

---

Installation and Initial Setup .....	3
Front Panel Features .....	4
Rear Panel Features .....	5
Input Module Installation.....	6
Compatible Input Formats.....	7
On-Screen Menu .....	8
STRUCTURE OVERVIEW .....	8
MAIN MENU AND NAVIGATION .....	9
VIDEO CONFIGURATION SUBMENU .....	9
MARKER CONFIGURATION SUBMENU .....	12
FILTER CONFIGURATION SUBMENU.....	16
SYSTEM CONFIGURATION SUBMENU .....	17
FUNCTION PRESETS SUBMENU .....	19
Specifications.....	20
Dimensions.....	21
Maintenance .....	22
Warranty .....	22

# Installation and Initial Setup

## ■ Unpacking

Carefully unpack the monitor and verify that the following items are included:

- MD-171 Monitor
- V-PS12-5V-XLR Power Supply with 4-Pin Male XLR Connector
- Operating Instructions

Inspect the unit for any physical damage that may have occurred during shipping. Should there be any damage, immediately call Marshall Electronics Customer Service at (800) 800-6608. If you are not located within the continental United States, call +1 (310) 333-0606.

## ■ Installation

The V-MD171X can be mounted in any standard EIA 19" equipment rack. The attached rack ears can be angled to provide the user control over the viewing angle. Adequate ventilation is required when installed to prevent possible damage to the monitor's internal components.

A VESA standard 75mm hole pattern also allows custom mounting installations. Alternately, the V-MD171X can be used in a desktop configuration with optional stand (Marshall part number **V-ST15**).

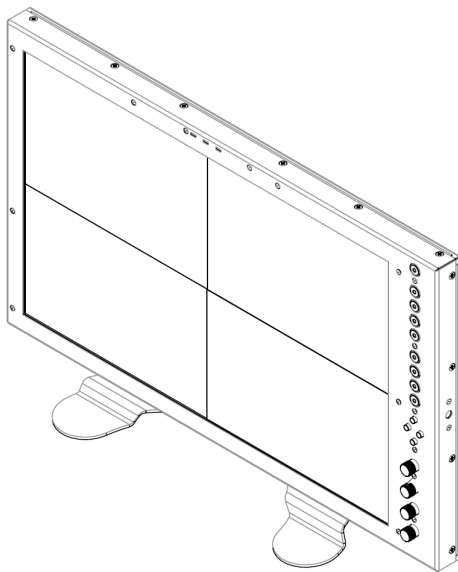

V-MD171X with optional desktop stand (Marshall Part Number V-ST15)

## ■ Input Slots

Install any optional input modules **BEFORE** applying power to unit. Please see detailed instructions on Page 9.

## ■ Connections and Power-On

Plug the V-PS12-5V-XLR power supply into an AC power source (100-240 V @ 50/60 Hz). Attach the 4-pin male twist-lock connector to the back of the monitor. The monitor draws a maximum of 3.0 Amps at 12 Volts in operation.

Connect the required cables for video signals, tally, etc. (Power must be applied to the V-MD171X for any of the active loop-through outputs to be activated.) All BNC connectors are rated at 75Ω.

The unit defaults to 'ON' when power is supplied.

# Front Panel Features

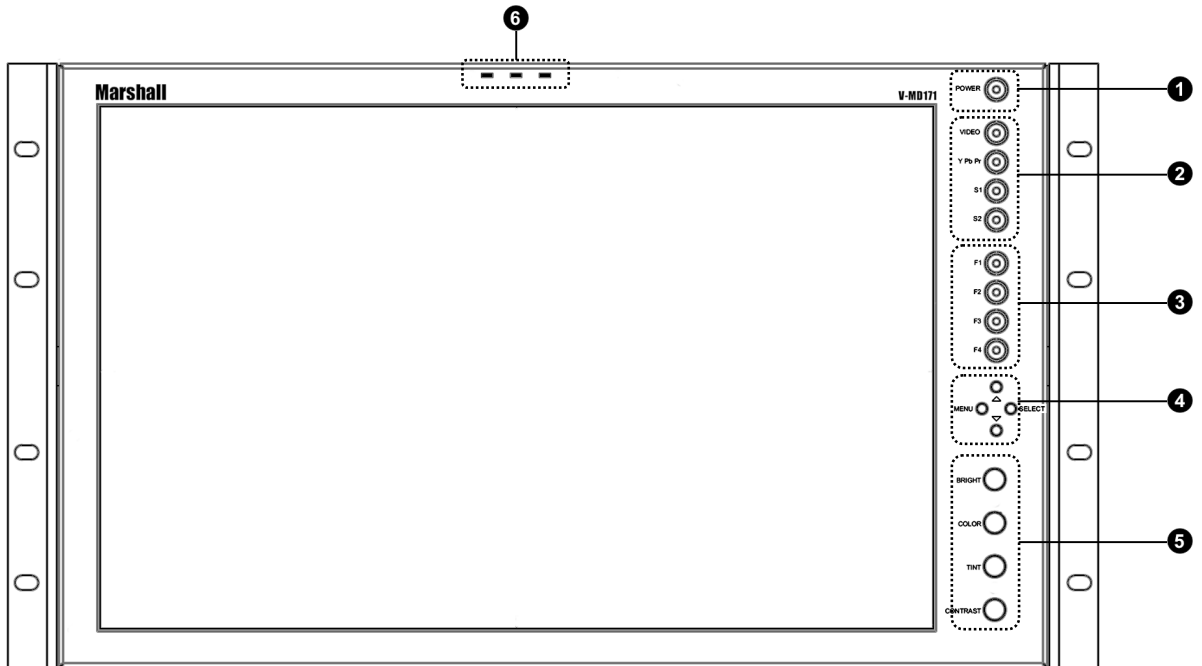

## 1 **Power Button**

Use the power button to toggle between ON and STANDBY modes. In both the STANDBY and the ON state, the LED on the button will illuminate bright green. This indicates that MAINS power is applied to the unit.

## 2 **Input Select Buttons**

Use the VIDEO, YPbPr, and S1/S2 buttons to select the corresponding analog or digital input. Video standards (NTSC/PAL, etc.) are automatically detected. S1/S2 select inputs connected to **Optional Input Modules** (located in Slot-1 or Slot-2).

## 3 **User-Definable Function Buttons**

Four user-definable function buttons can be used for direct access to various settings. Functions are assigned using the on-screen menu (**Function Presets – Page 21**).

## 4 **Menu Navigation Buttons**

Use the Menu, ▲, ▼, and Select buttons to display and navigate the on-screen menu (**See Main Menu and Navigation – Page 12**).

## 5 **Image Adjustment Knobs**

Use the image adjustment knobs to adjust color brightness, color-saturation, tint, and contrast of the image. The status of each image adjustment parameter is shown on the bottom left of the screen, with values ranging from 0 to 100. Default value is 50.

## 6 **LED Tally**

Three LED tally lights (yellow, red, green) are available above the screen. Each tally light can be controlled independently from the rear Tally Connector. (**See Tally Hardware Interface, Page 22.**)

# Rear Panel Features

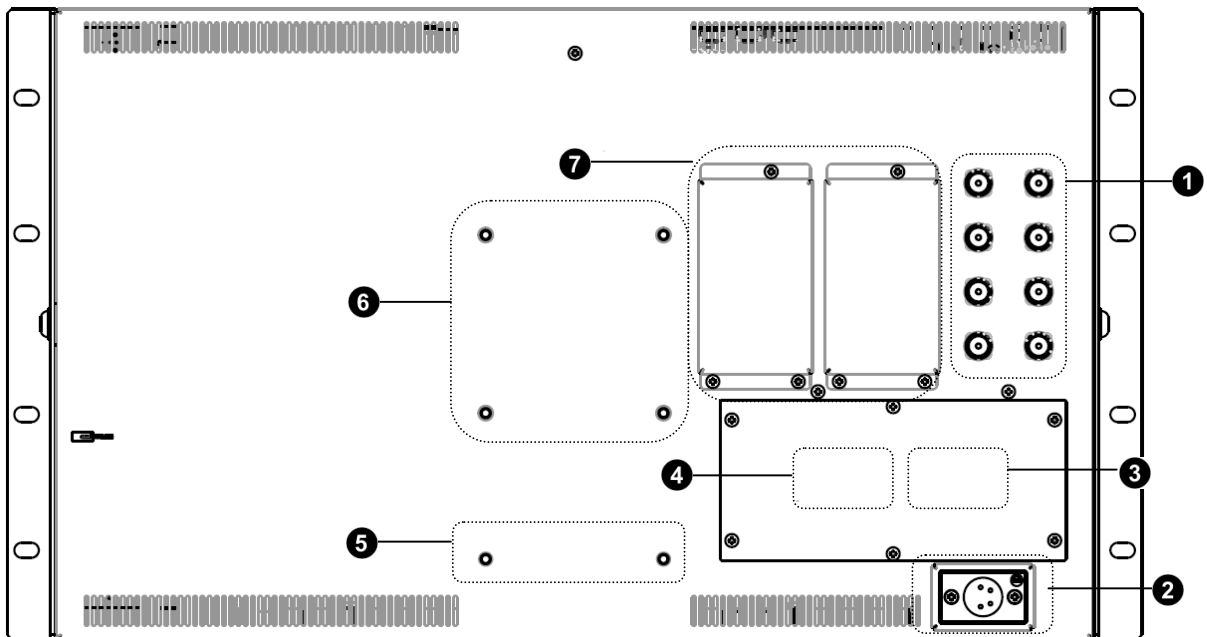

## 1 Component and Composite Input and Output

The V-MD171X has HD/SD component (YPbPr) and composite analog input. There is an active loop-through output for each analog input. See page 10 for supported video formats. The BNC inputs are internally terminated with 75 ohms. Outputs are active ONLY when power is supplied to unit.

## 2 Power Input

Connect 12VDC to the 4-pin XLR power input connector. Power should only be supplied from the included power supply.

**IMPORTANT:** If using a power source other than the included power supply, damage may result. Please use the pin out diagram in the Specifications section of these Operating Instructions.

## 3 Tally Input Connector (HD-15)

The LED tally can be activated via the HD-15 connector by connecting the corresponding pin to ground. A variety of external devices can be used to perform the contact closure. No additional power should be supplied to the HD-15 port. **See pin-out details on page 22.**

## 4 Programming Connector CN1\*

For Factory Use ONLY.

\*NOTE\* although this appears to be a standard USB connector, It is NOT. Do not connect to any computer directly.

## 5 Desktop Mounting Holes

These holes are used when attaching the monitor to the optional desktop stand.

**See page 5 for details**

## 6 VESA 75mm Hole Pattern

VESA-standard 75 mm hole-pattern is provided to accommodate a variety of custom mounting options.

## 7 Input Slots, S1 and S2

The V-MD171X has 2 slots for optional input modules. These modules allow for a wide variety of input types and configurations. Modules are COLD swappable and must only be inserted or removed ONLY when Main Power is UPPLUGGED.

# Input Module Installation

---

## 1. Remove Power From Unit

- Modules are cold-swappable only. Damage will occur if modules are inserted or removed while unit is powered.

## 2. Remove Blank Module Cover

- Using Philips screwdriver, remove the 4-40x1/8" screws. There are a total of three screws, save them for later use.
- Remove blank cover

## 3. Insert Optional Module

- Decide which slot you intend to install module (Slot 1 or Slot 2)
- Carefully align the module with the chosen slot. The raised rails will fit inside the module
- Align the Module so that the three (3) mounting holes all line up with the threaded holes of the slot.
- The connectors on both the module and the main-board slot should now be in alignment.
- Carefully PRESS the module into the slot. Module will seat flush with the rear of the unit.
- Replace the three (3) screws removed in Step 2.

\*NOTE\* Use ONLY 4-40x1/8" screws provided. Any screw longer than 1/8" will damage the main unit.

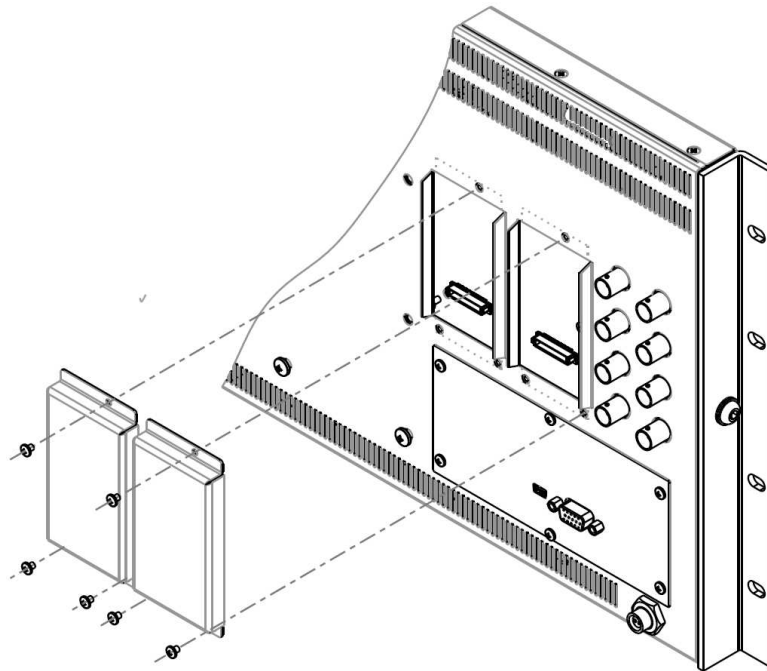

# Compatible Input Formats

---

## CVBS and YPbPr Analog Inputs

**VIDEO** : NTSC 480i 59.94, PAL 525i 50

**YPbPr:**

480i 59.94, 576i 50  
480p 59.94, 576p 50  
720p (60 / 59.94 / 50 / 30 / 29.97 / 25)  
1080i (60 / 59.94 / 50)  
1080p (30 / 29.97 / 25 / 24 / 24sF / 23.98 / 23.98 sF)

## MD-3GSDI-A and MD-TC-A– 3G/HD/SDI Input Module and 3G/HD/SDI Telecube Input module

**SD-SDI –**

480i 59.94, 576i 50

**HD-SDI –**

720p (60 / 59.94 / 50 / 30 / 29.97 / 25)  
1080i (60 / 59.94 / 50)  
1080p (30 / 29.97 / 25 / 24 / 24sF / 23.98 / 23.98sF)

**3G-SDI – YCbCr (4:2:2) 10 Bit – Level A and B**

1080p (60 / 59.94 / 50)  
**YCbCr/RGB (4:4:4) 10 Bit – Level A and B**  
1080i (60 / 59.94 / 50)  
1080p (30 / 29.97 / 29.97sF / 25 / 25sF / 24 / 24sF / 23.98 / 23.98sF)

## MD-HDSDIx2-A – Two-channel HDSDI Input Module with Switched Output

**SD-SDI –**

480i 59.94, 576i 50

**HD-SDI –**

720p (60 / 59.94 / 50 / 30 / 29.97 / 25)  
1080i (60 / 59.94 / 50)  
1080p (30 / 29.97 / 25 / 24 / 24sF / 23.98 / 23.98sF)

## MD-DVII-A – DVI-I Input Module

**DVI-D Video (YCbCr or RGB)**

480p 59.94, 576p 50  
720 (59.94 / 60 / 50 / 25 / 29.97 / 30 )  
1080i (50 / 59.94 / 60)  
1080p (23.97 / 24, / 29.97 / 30 / 24 / 24sF / 23.98 / 23.98sF)

**PC Formats – DVI-D and DVI-A**

640 x 480 60, 72, 75  
800 x 600 60, 72, 75  
1024 x 768 60 70  
1280 x 1024 60  
1600 x 1200 60  
1920 x 1200 60

## MD-HDMIx2-A – Two-channel HDMI Input Module

**HDMI Video (YCbCr or RGB)**

480p 59.94, 576p 50  
720 (59.94 / 60 / 50 / 25 / 29.97 / 30 )  
1080i (50 / 59.94 / 60)  
1080p (23.97 / 24, / 29.97 / 30 / 24 / 24sF / 23.98 / 23.98sF)

**PC Formats – DVI-D**

640 x 480 60, 72, 75  
800 x 600 60, 72, 75  
1024 x 768 60 70  
1280 x 1024 60  
1600 x 1200 60  
1920 x 1200 60

# On-Screen Menu

## STRUCTURE OVERVIEW

Main Menu	Video Configuration	Color Temperature	D65, D55, Linear, User, D93
		Gamma <sup>1</sup>	2.2, 2.4, 1.8, 2.0,
		RGB Bias and Gain <sup>1</sup>	R, G, B Gain (0-100) / R, G, B Bias (0-100)
		Check Field	Off, Mono, Blue, Green, Red
		Ratio <sup>2</sup>	Full Screen, 4:3, 16:9
		Pixel-to-Pixel	Off, On
		H/V Delay <sup>2,5</sup>	Off, H/V Delay, V Delay, H Delay
		Underscan <sup>3</sup>	Off, On
		NTSC Black Level <sup>4</sup>	0 IRE, 7.5 IRE
	Marker Configuration	Markers	Off, On
		Center Marker	Off, On
		16:9 Markers	Off, 4:3, 13:9, 14:9, 1.85:1, 2.35:1, 95% Safe, 93% Safe, 90%Safe, 88% Safe, 85% Safe, 80% Safe, User
		Full Screen Markers	Off, 95% Safe, 93% Safe, 90%Safe, 88% Safe, 85% Safe, 80% Safe, User
		4:3 Markers	Off, 95% Safe, 93% Safe, 90% Safe, 88% Safe, 85% Safe, 80% Safe, User
		Marker Background	100%, 75%, 50%, 25%, 0%
	Filter Configuration	False Colors	Off, On
		Mosquito Filter	Off, On
	System Configuration	Input Format OSD	5 sec, On, Off
		Curtain Color	Blue, Black, Green
		Splash Screen	On, Off
		Freeze Input	Off, On
		Load Setup	MFG Default, User 1, User 2, User 3, User 4, User 5, User 6
		Save Setup	User 1, User 2, User 3, User 4, User 5, User 6
		Power On Preset	Off, User 1, User 2, User 3, User 4, User 5, User 6, MFG Default
	Function Presets	Function on F1	Ratio, Check Field, Mosquito Filter, False Colors, Freeze Input, Aspect Markers, Center Marker, Markers, Underscan, H/V Delay, Pixel-to-Pixel
		Function on F2	Ratio, Check Field, Mosquito Filter, Peaking Filter, False Colors, Freeze Input, Aspect Markers, Center Marker, Markers, Underscan, H/V Delay, Pixel-to-Pixel
		Function on F3	Ratio, Check Field, Mosquito Filter, Peaking Filter, False Colors, Freeze Input, Aspect Markers, Center Marker, Markers, Underscan, H/V Delay, Pixel-to-Pixel
		Function on F4	Ratio, Check Field, Mosquito Filter, Peaking Filter, False Colors, Freeze Input, Aspect Markers, Center Marker, Markers, Underscan, H/V Delay, Pixel-to-Pixel

<sup>1</sup> Disabled when Color Temperature is set to Linear

<sup>2</sup> Disabled when Pixel to Pixel is ON

<sup>3</sup> Available only with Composite NTSC or PAL Input

<sup>4</sup> Available only with Composite NTSC Input

### MAIN MENU AND NAVIGATION

Access the main menu by pushing the **MENU** button on the front panel of the monitor.

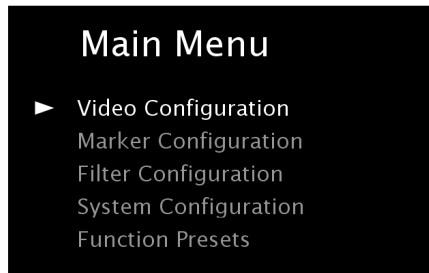

*Main Menu*

- Step through menu items using the ▲ and ▼ buttons.
- Choose a submenu or select a menu item by pressing **SELECT**.
- Return to the previous menu by pressing **MENU**.
- Exit the main menu by pressing **MENU**. The menu will automatically time out after approximately 15 seconds.

### VIDEO CONFIGURATION SUBMENU

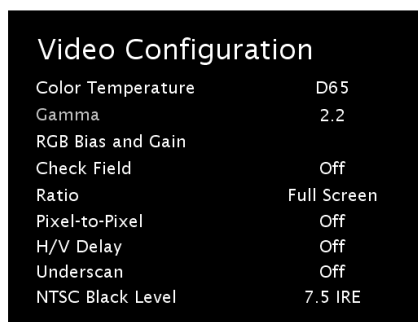

*Video Configuration Submenu*

#### ■ Color Temperature

Use this setting to choose one of five color temperature presets:

- D65 (5500K)
- D55 (6500K)
- D93 (9300K)
- USER (Adjustable Color Bias and Gain)
- Linear

#### ■ Gamma

Use this setting to choose one of four selectable Gamma tables:

- 2.2
- 2.4
- 1.8
- 2.0

Note: Gamma is disabled when **Color Temperature** is set to **Linear**

## On-Screen Menu (continued)

### ■ RGB Bias and Gain

Select this submenu to fine-tune the monitor's color balance (R, G, B). This should only be done by someone experienced with video engineering, as this will alter the overall color shading of the screen. The purpose is to allow color matching to other types of monitors and/or displays. Note: The Color Temperature preset will automatically switch to USER when Color Bias settings are adjusted. It is normal for color bias adjustments to be very subtle.

When selecting the RGB Bias and Gain submenu, gain adjustment indicators will appear at the top of the screen, and bias adjustment indicators will appear at the bottom of the screen:

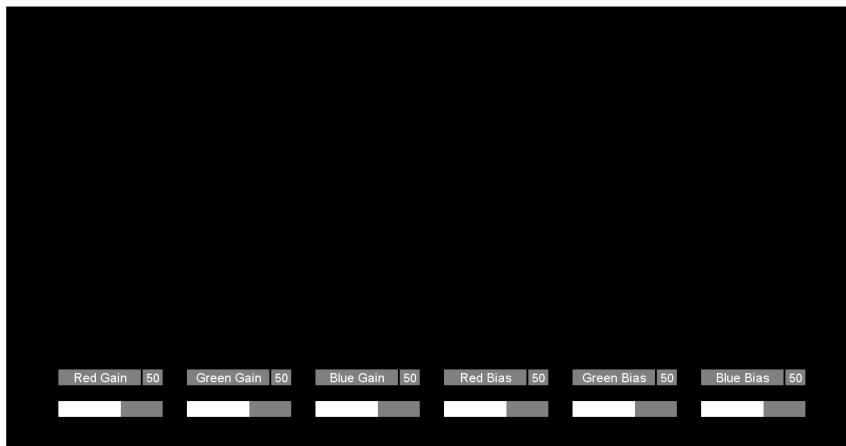

*RGB Bias and Gain Submenu*

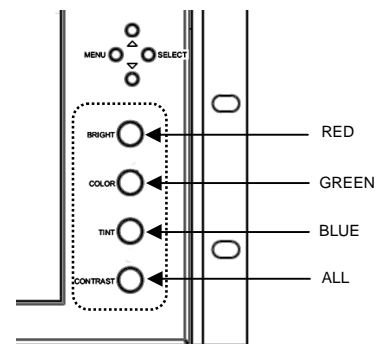

Use the ▲ and ▼ buttons to select each individual bias or gain control. Press SELECT to begin adjusting the control. Use the ▲ and ▼ buttons to increase or decrease the value.

Alternately, the image adjustment knobs (Brightness, Color, Tint, Contrast) can be used to easily adjust the bias and gain settings as shown below. The knobs affect whichever row of controls (gain or bias) is currently selected.

Note: RGB Gain and Bias is disabled when **Color Temperature** is set to **Linear**.

### ■ Check Field

Use the check field modes for monitor calibration or to analyze individual color components of an image. In Monochrome mode, all color is disabled and only a grayscale image is shown. In Blue, Green, and Red check field modes, only the selected color will be shown.

### ■ Ratio (Aspect Ratio Settings)

Use to switch between Full Screen, 4:3 and 16:9 aspect ratios.

As the V-MD171X monitor has a native resolution of 1920 x 1200 RGB pixels, incoming images are automatically scaled to fit the screen:

- In Full Screen, images are scaled to fill the entire screen.
- In 4:3 mode, images are scaled to fill the maximum 4:3 portion of the screen, with black bars filling the remainder of the screen edges.
- In 16:9 mode, images are scaled to fill the maximum 16:9 portion of the screen (1920 x 1080), with black bars filling the remainder of the screen.

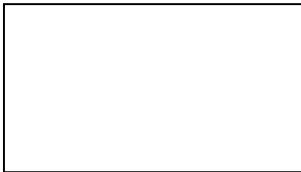

Full Screen

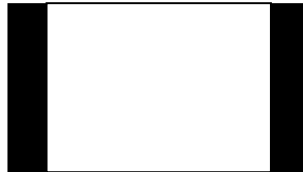

4:3 Mode



16:9 Mode

Note: The aspect ratio setting is ignored when **Pixel-to-Pixel** mode is **ON**.

### ■ Pixel-to-Pixel Mode

Use this setting to enable Pixel-to-Pixel mode.

This mode bypasses the monitor's internal scaling function and displays incoming images in their native resolution and aspect ratio, with a one-to-one mapping:

- For incoming formats smaller than the native resolution of the LCD panel (1920 x 1200), the image will be displayed in the center of the screen using only the necessary LCD pixels. For example, NTSC images will occupy exactly 720 x 480 pixels. The surrounding pixels will be black.

Note: Pixel-to-Pixel mode disables aspect ratio control and H/V Delay.

### ■ H/V Delay

Use this setting to enable one of three delay modes (H & V Delay, V Delay, H Delay):

- In H & V Delay mode, both horizontal sync and vertical sync are delayed, resulting in both horizontal and vertical blanking periods being shown on the screen.
- In V Delay mode, vertical sync is delayed so that the vertical blanking period is displayed on screen.
- In H Delay mode, horizontal sync is delayed so that the horizontal blanking period is displayed on the screen.

Notes: H/V Delay is disabled when **Pixel-to-Pixel** mode is **ON**.

H/V Delay is only available with Composite inputs (NTSC or PAL)

### ■ Underscan

Use this setting to enable or disable Underscan mode:

- When Underscan is OFF, the active portion of the video signal is displayed on the screen, with 0% overscan.
- When Underscan is ON, the image size is slightly reduced. This allows the user to clearly view the edges of the active video area.

Note: Underscan is only available with Composite inputs (NTSC or PAL)

### ■ NTSC Black Level

Set the NTSC Black Level according to the type of NTSC composite video input:

- 7.5 IRE: Use this setting for standard NTSC-M signals which use a 7.5 IRE setup (black level).
- 0 IRE: Use this setting for NTSC-J signals which have no setup, or a black level of 0 IRE.

Note: This setting is disabled for PAL composite input and all component/3G-SDI formats.

## MARKER CONFIGURATION SUBMENU

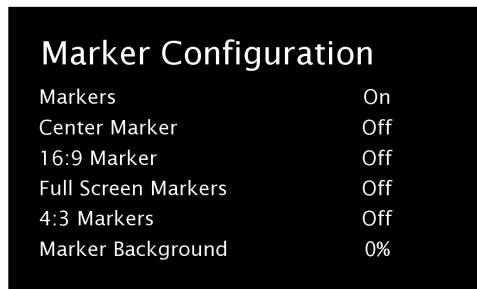

Marker Configuration	
Markers	On
Center Marker	Off
16:9 Marker	Off
Full Screen Markers	Off
4:3 Markers	Off
Marker Background	0%

*Marker Configuration Submenu*

### ■ Markers

Use this setting to enable or disable all on-screen markers. This setting affects the center marker, full screen markers, 16:9 markers, and 4:3 markers.

### ■ Center Marker

Use this setting to display a center marker on the screen.

### ■ 16:9 Markers

Use these settings to superimpose one of the selectable markers on the screen when in 16:9 ratio mode.

- Off (no marker)
- 4:3
- 13:9
- 14:9
- 1.85:1
- 2.35:1
- 95% Safe
- 93% Safe
- 90% Safe
- 88% Safe
- 85% Safe
- 80% Safe
- User

### MARKER CONFIGURATION SUBMENU (continued)

#### 16:9 Marker Examples:



OFF (No Marker)

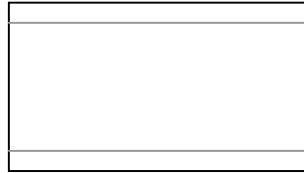

2.35:1 Aspect Ratio



4:3 Aspect Ratio Markers



90% Safe Area

#### ■ Full Screen Markers

Use this setting to superimpose one of the selectable markers on the screen when in Full Screen ratio mode. This setting is disabled when the aspect ratio is set to 16:9, or when Pixel-to-Pixel, Underscan, or H/V Delay is enabled.

- Off (no marker)
- 95% Safe Area
- 93% Safe Area
- 90% Safe Area
- 88% Safe Area
- 85% Safe Area
- 80% Safe Area
- User

#### 4:3 Marker Examples:



OFF (No Marker)

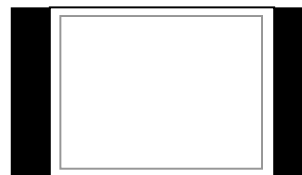

90% Safe Area

#### ■ 4:3 Markers

Use this setting to superimpose one of the selectable markers on the screen when in 4:3 ratio mode. This setting is disabled when the aspect ratio is set to 16:9, or when Pixel-to-Pixel, Underscan, or H/V Delay is enabled.

- Off (no marker)
- 95% Safe Area
- 93% Safe Area
- 90% Safe Area
- 88% Safe Area
- 85% Safe Area
- 80% Safe Area
- User

### MARKER CONFIGURATION SUBMENU (continued)

#### ■ Marker Background

Use this setting to choose how outer edges of the markers are displayed on the screen:

- 100% Image area beyond the marker is shown at solid black
- 75%
- 50% Image area beyond the marker is shown at 50% Transparent overlay
- 25%
- 0% Only The marker is superimposed on the image.

**Example (80% Marker in 4:3 Mode):**



*Normal Background*



*Black Background*

#### User Markers

User markers enable the user to create their own safe areas on the screen.

1. Choose the User option for your selected aspect ratio (Full Screen, 4:3 or 16:9) in the Marker Configuration submenu and press the SELECT button. You may also begin with an already predefined safe area (95%, 93%, 90%, etc.) and make your adjustments from there by highlighting a particular safe area and pressing the SELECT button.

Marker Configuration	
Marker Enable	On
Center Marker	Off
16:9 Marker	Off
Full Screen Markers	User
4:3 Markers	Off
Marker Background	100%

2. Use the BRIGHT, COLOR, TINT and CONTRAST knobs to move the LEFT, RIGHT, TOP and BOTTOM borders of the safe area to your desired position. When you have reached the desired location for the borders, press the MENU button. If you began the marker adjustment using one of the predefined safe areas and made an adjustment, the marker selection will automatically convert to the User marker setting.

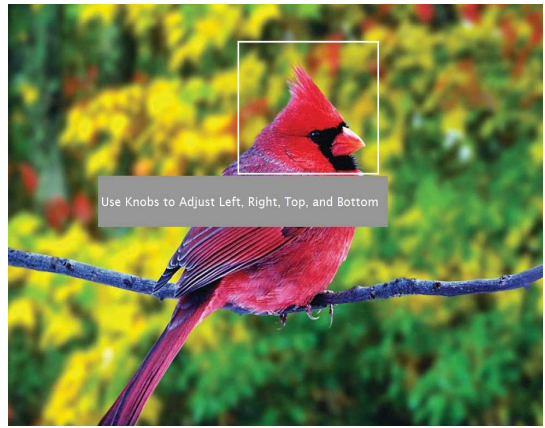
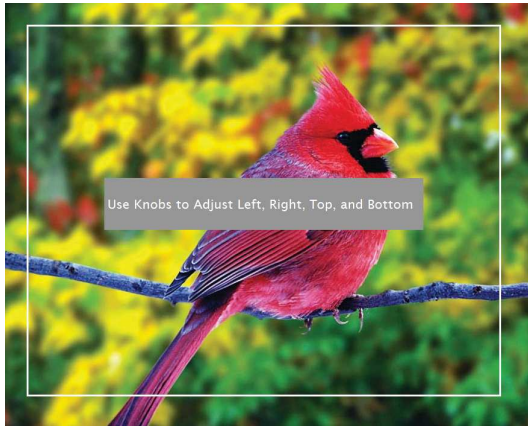

### FILTER CONFIGURATION SUBMENU

#### ■ False Colors

This monitor has a false color filter to aid in the setting of camera exposure. As the camera Iris is adjusted, elements of the image will change color based on the luminance or brightness values. This enables proper exposure to be achieved without the use of costly, complicated external equipment. To best utilize this feature, you must understand the color chart below and have a basic understanding of camera exposure. Normally, when shooting subjects like people, it is common practice to set exposure of faces to the equivalent of approximately 56 IRE. The false color filter will show this area as the color PINK on the monitor. Therefore, as you increase exposure (open the IRIS), your subject will change color as indicated on the chart: PINK, then GREY, then a few shades of YELLOW. Over exposed subjects (above 101 IRE) on the monitor will be shown as RED. In addition, underexposed subjects will show as DEEP-BLUE to DARK-BLUE, with clipped-blacks indicated with a FUCHSIA-like color. Lastly, the color GREEN is used to indicate elements of the image that are approximately 45 IRE. This represents a 'neutral' or 'mid-level' exposure commonly used for objects (not people).

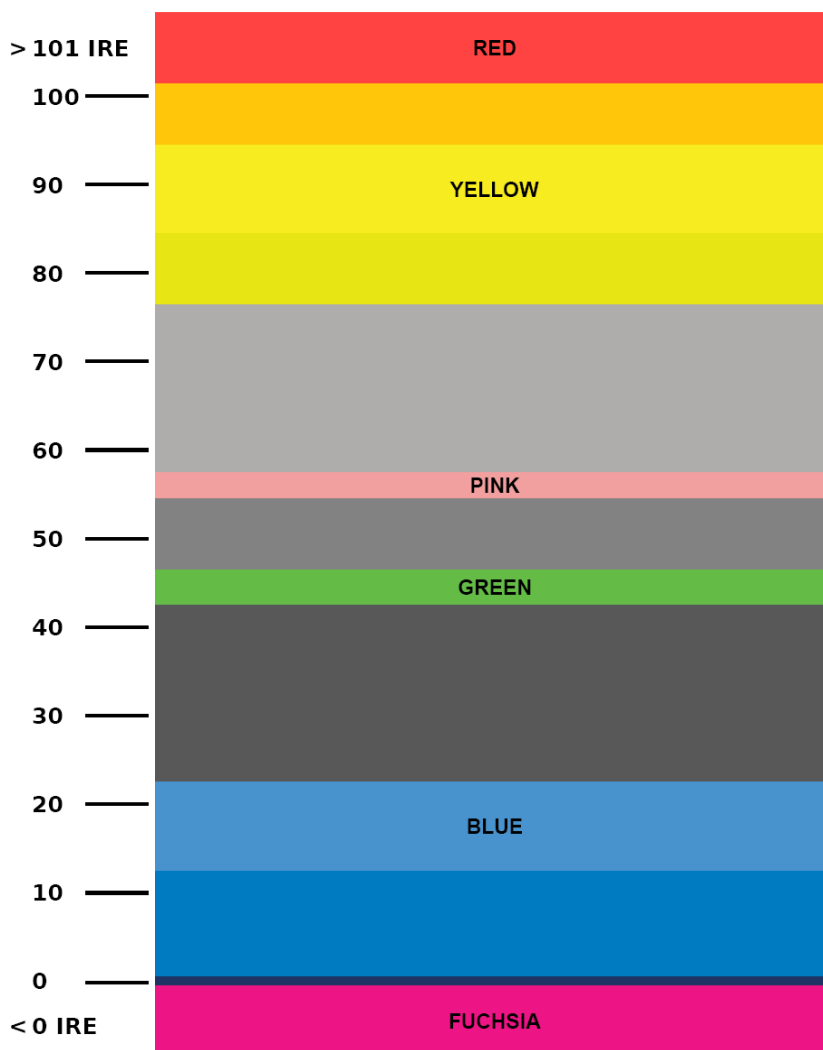

False Color Key

### FILTER CONFIGURATION SUBMENU (continued)

#### ■ Mosquito Filter

Use this setting to filter out “Mosquito Noise” – an artifact that appears as specs around edges of objects. This artifact is the result of video that has been compressed at some point. Video sources from DVD-Players, PDA's, Digital Cable Boxes, Camcorders, etc. often have this artifact.

### SYSTEM CONFIGURATION SUBMENU

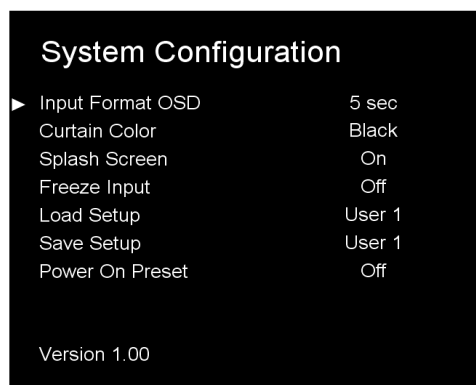

*System Configuration Submenu*

#### ■ Input Format OSD

Use this option to enable on-screen display of input/format status in the upper-left corner of the screen. Options are: Off, On or 5 Sec. When 5 Sec selected, On Screen display whenever a new input is received, then after approximately 5 seconds, the text will disappear.

#### ■ Curtain Color

Selects the color of the screen whenever there is no input, or if input is lost. Choices are: Blue, Black or Green.

#### ■ Splash Screen

The Splash Screen is what is displayed when the monitor is first powered. The text “Marshall Electronics” is displayed along with the model name of the unit. This feature can be turned off.

## On-Screen Menu (continued)

### SYSTEM CONFIGURATION SUBMENU (continued)

#### ■ Freeze Input

Use the Freeze function to “freeze” the current image on the screen. Select this menu item again (Off) to return to the real-time video input.

#### ■ Load Setup

Up to 6 User Setups can be stored on this monitor. Load Setup allows instant recall of any of the 6 saved configurations (User 1-6). Also available is the ability to load factory default settings. (MFG Default)

#### ■ Save Setup

Up to 6 User Setups can be stored on this monitor. Save Setup allows the current configuration to be saved in one of 6 named locations in memory. (User 1-6). Settings are saved even if power is lost from the unit.

#### ■ Power on Preset

Selects what preset configuration is loaded each time the monitor is powered. Choices are: Off – (last used configuration), User 1-6, or MFG Default.

### FUNCTION PRESETS SUBMENU

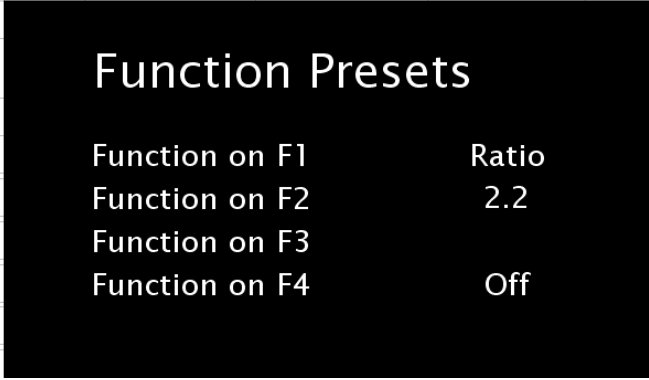

Function Presets	
Function on F1	Ratio
Function on F2	2.2
Function on F3	
Function on F4	Off

#### ■ Function Presets

Allows user to assign menu items to the front panel function buttons: **F1, F2, F3 and F4**. The following options are available for each button:

- Ratio
- Check Field
- Mosquito Filter
- False Colors
- Freeze Input
- Aspect Markers
- Center Marker
- Markers
- Underscan
- H/V Delay
- Pixel-to-Pixel

# Specifications

## ■ PANEL

Screen Size	17.0" Diagonal
Display Area (h x v)	367.20 x 229.50 mm
Aspect Ratio	16:10 Native (4:3/16:9 Selectable)
Pixels	1920 x RGB x 1200
Viewing Angle (h x v)	140° x 120°
Brightness	330 cd/m <sup>2</sup>
Contrast Ratio	500:1
Dot Pitch (h x v)	0.064 x 0.191 mm
Pixel Pitch (h x v)	0.191 x 0.191 mm

Pin #	Screen #	Function
1	1	Green
2		Red
3		Yellow
4		GROUND
5		GROUND
6		N/C
7		N/C
8		N/C
9		N/C
10		N/C
11		N/C
12		N/C
13		N/C
14		N/C
15		N/C

## ■ VIDEO INPUT/OUTPUT

**Video Input / Output (Composite)**  
Supports SMPTE 170M, NTSC/PAL

**YPbPr Input / Output (Component)**  
Supports SMPTE 260M, 274M, 296M

## ■ CONNECTORS

### Video Input

Video (Composite)	1 x BNC Female (75 Ω)
YPbPr (Component)	3 x BNC Female (75 Ω)

### Video Output (Active Loop-Through)

Video (Composite)	1 x BNC Female (75 Ω)
YPbPr (Component)	3 x BNC Female (75 Ω)

### S1, S2 (Module Slots)

For Marshall I/O Modules Only  
Cold-Swap – remove power from unit before  
Inserting or removing Modules.

### Power Input

4-Pin XLR Connector

### Tally Hardware Interface

HD-15 Female

### CN-1 – Programming Port\*

\* NOT USB – Factory Use Only

## ■ TALLY HARDWARE INTERFACE (HD-15)

Activation requires contact closure of pin to ground on the HD-15 connector:

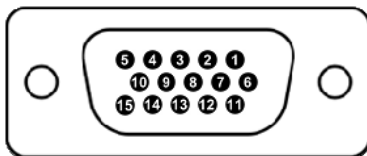

Female HD-15 Connector

## ■ ELECTRICAL

Power Consumption  
ON: 3.5 Amp @ 12VDC (42 W Max)

Voltage Requirement 12VDC

V-PS12-5V-XLR Power Supply:

Input	100V-240V, 1.5A, 50-60Hz
Output	12VDC, 5A, 60W Max

Power Input 4-Pin XLR

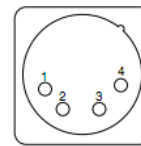

Pin number	Signal
1	GND
2, 3	—
4	+12 V

## ■ MECHANICAL

Dimensions (w x h x d): 18.84" x 10.45" x 1.00"

Weight (Monitor Only): 7.5 lbs

Additional Mounting: Desk Stand  
Marshall Part # V-ST15

Standard VESA 75mm Mount

Operating Temperature 32°F to 104°F (0°C to 40° C)  
Storage Temperature -4°F to 120°F (-20°C to 50° C)

RoHs Do not dispose. Return to  
Manufacturer or Authorized  
Recycle Facility.

# Dimensions

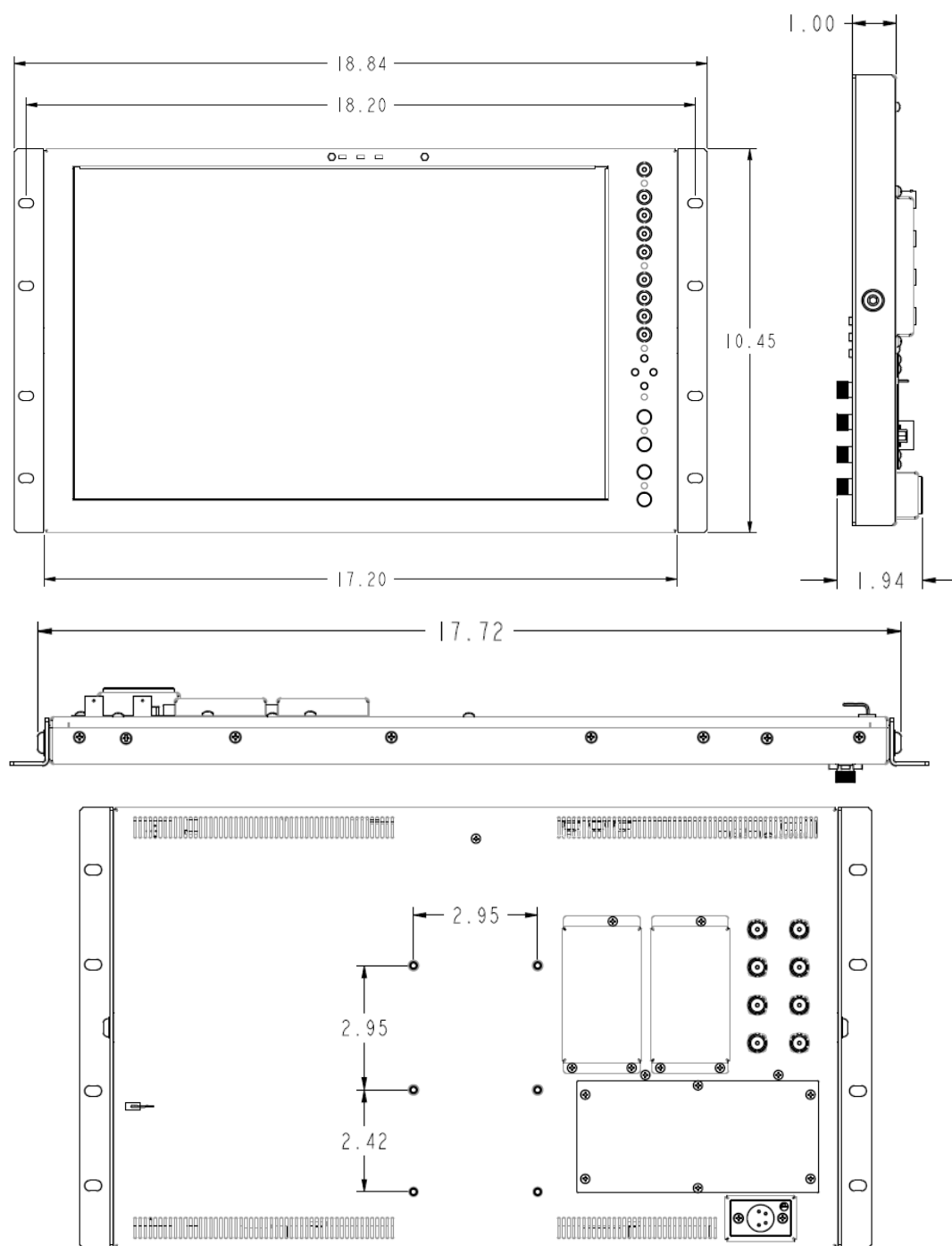

# Maintenance

---

## ■ Screen Cleaning

Periodically clean the screen surface using ammonia-free cleaning wipes (Marshall Part No. **V-HWP-K**). A clean micro-fiber cloth can also be used using only non-abrasive and ammonia-free cleaning agents. Do not use paper towels. Paper towel fibers are coarse and may scratch the surface of the panel or leave streaks on the surface. Antistatic and fingerprint resistant cleaning agents are recommended. Do not apply excessive pressure to the screen to avoid damaging the LCD.

# Warranty

---

Marshall Electronics warranties to the first consumer that this **V-MD171X** LCD monitor will, under normal use, be free from defects in workmanship and materials, when received in its original container, for a period of one year from the purchase date. This warranty is extended to the first consumer only, and proof of purchase is necessary to honor the warranty. If there is no proof of purchase provided with a warranty claim, Marshall Electronics reserves the right not to honor the warranty set forth above. Therefore, labor and parts may be charged to the consumer. This warranty does not apply to the product exterior or cosmetics. Misuse, abnormal handling, alterations or modifications in design or construction void this warranty. *It is considered normal for a minimal amount of pixels, not to exceed three, to fail on the periphery of the display active viewing area.* Marshall Electronics reserves the option to refuse service for display pixel failure if deemed unobtrusive to effective use of the monitor by our technicians. No sales personnel of the seller or any other person is authorized to make any warranties other than those described above, or to extend the duration of any warranties on behalf of Marshall Electronics, beyond the time period described above. Due to constant effort to improve products and product features, specifications may change without notice.

**Marshall Electronics, Inc.**

1910 East Maple Ave.  
El Segundo, CA 90245

Tel: (800) 800-6608 / (310) 333-0606 • Fax: 310-333-0688

[www.LCDRacks.com](http://www.LCDRacks.com) • [sales@lcdracks.com](mailto:sales@lcdracks.com)